

BETA

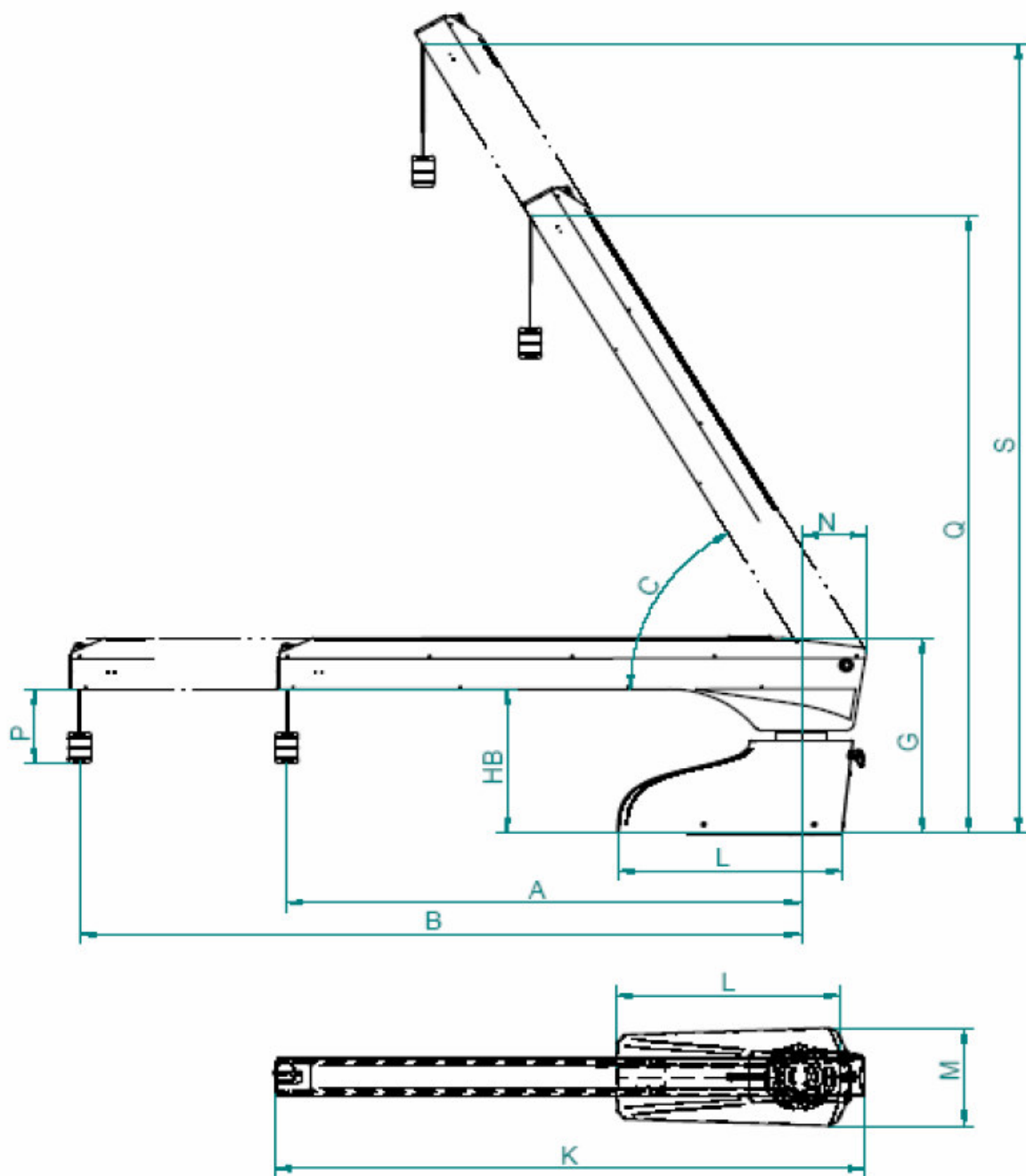

Diagramma di lavoro / Working area

Ingombri / Size

Modello / Model	Portata / Capacity (kg)	Angolo Alzata / Lifting Angle (°)	Sbraccio / Extension (mm)		Altezza / Height (mm)		Rotazione / Rotation (°)	Lunghezza cavo / Cable length (mm)	Base / Base (mm)			Altezza / Height (mm)	Altezza sotto braccio / Under extension (mm)	Proiezione / Total length (mm)	Peso / Weight (kg)
			min(A)	max(B)	min(Q)	max(S)			(L)	(M)	(N)				
BETA		(C)					(D)	(P)	(L)	(M)	(N)	(G)	(HB)	(K)	kg
25	400	0°	1750	2500	560	560	359°	5000	950	490	210	760	560	2110	320
		60°	750	1250	2310	2950									
30	400	0°	2000	3000	560	560	359°	5000	950	490	210	760	560	2610	360
		60°	1000	1500	2760	3400									