

# GFT-800

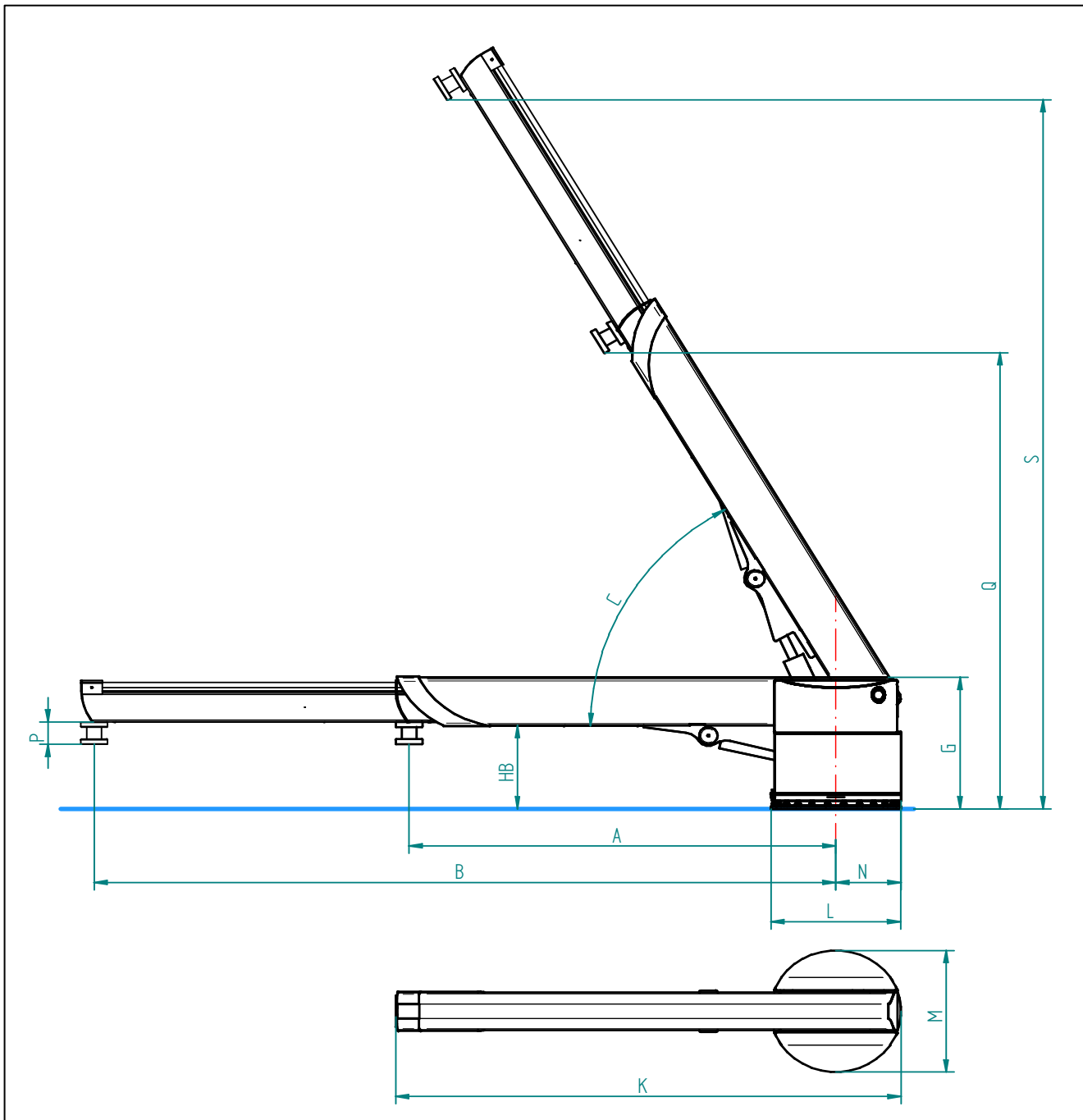

		Diagramma di lavoro / Working area							Ingombri / Size					Peso / Weight	
Modello / Model	Portata / Capacity	Angolo Alzata / Lifting Angle	Sbraccio / Extension		Altezza / Height		Rotazione / Rotation	Lunghezza cavo / Cable length	Base / Base			Altezza / Height	Altezza sotto braccio / Under jib	Proiezione / Total length	
Unit	kg	°	mm	mm	mm	mm	°	mm	mm	mm	mm	mm	mm	mm	kg
GFT		(C)	(A)	(B)	min (Q)	max (S)	(D)	(P)	(L)	(M)	(N)	(G)	(HB)	(K)	
<b>35</b>	800	0°	2050	3500	300	300	359	6350	700	700	350	766	485	2480	650
		60°	1025	1750	2300	3280									
<b>40</b>	800	0°	2300	4000	300	300	359	7320	700	700	350	766	485	2730	750
		60°	1150	2000	2650	4120									

\* centralina idraulica non inserita nel basamento - \* hydraulic unit not inserted in the base